

COLORADO™ 1-TRI TOUR

User Manual

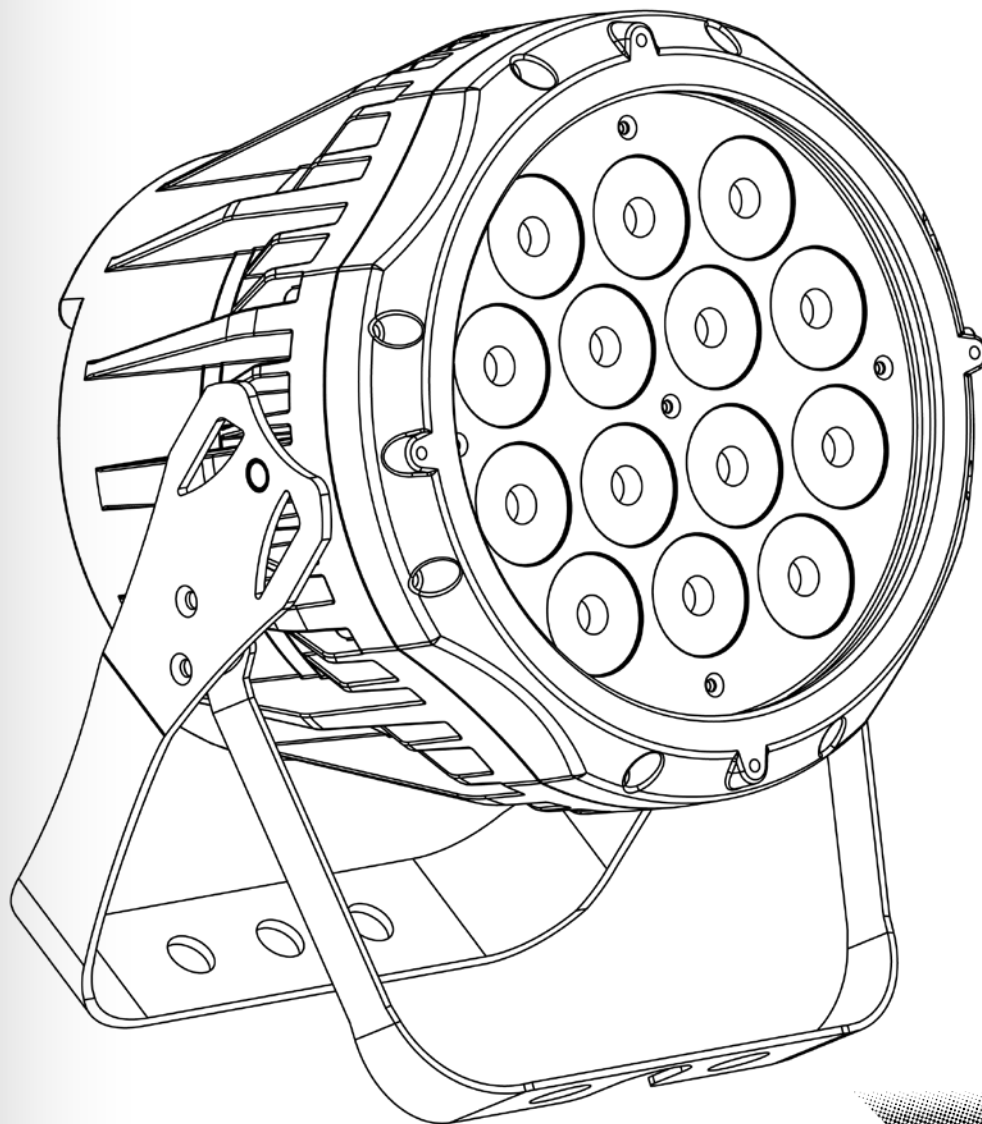

CHAUVET
PROFESSIONAL[®]
It's **Green** Thinking.

Edition Notes The COLORado™ 1-TRI TOUR User Manual Rev. 2 covers the description, safety precautions, installation, programming, operation, and maintenance of the COLORado™ 1-TRI TOUR. CHAUVET® released this edition of the COLORado™ 1-TRI TOUR User Manual Rev. 2 in March 2014.

Trademarks CHAUVET® is a registered trademark of CHAUVET & Sons Inc. (d/b/a CHAUVET® or Chauvet). The CHAUVET® logo in its entirety, including the CHAUVET® name and the dotted triangle, and all other trademarks in this manual pertaining to services, products, or marketing statements (example: It's Green Thinking™) are owned or licensed by CHAUVET®. Any other product names, logos, brands, company names, and other trademarks featured or referred to within this document are the property of their respective trademark holders.

Copyright Notice CHAUVET® owns the content of this User Manual in its entirety, including, but not limited to, pictures, logos, trademarks, and resources.

© **Copyright 2014 CHAUVET®. All rights reserved.**

Electronically published by CHAUVET® in the United States of America.

Manual Use CHAUVET® authorizes its customers to download and print this manual for professional information purposes only. CHAUVET® expressly prohibits the usage, copy, storage, distribution, modification, or printing of this manual or its content for any other purpose without written consent from CHAUVET®.

Document Printing For better results, print this document in color, on letter size paper (8.5 x 11 in), double-sided. If using A4 paper (210 x 297 mm), configure your printer to scale the content accordingly.

Intended Audience Any person in charge of installing, operating, and/or maintaining this product should completely read through the guide that shipped with the product, as well as this manual, before installing, operating, or maintaining this product.

Disclaimer CHAUVET® believes that the information contained in this manual is accurate in all respects. However, CHAUVET® assumes no responsibility for any errors or omissions in this document. CHAUVET® reserves the right to revise and make changes to the content of this document without obligation that CHAUVET® notify any person or company of such revision or changes. This does not in any way constitute a commitment by CHAUVET® to make such changes. CHAUVET® may issue a revision of this manual or a new edition to incorporate such changes.

Document Revision The COLORado™ 1-TRI TOUR User Manual Rev. 2 supersedes all previous versions of this manual. Discard any older versions of this manual and replace with this version.

| Author | Date | Editor | Date |
|----------|----------|---------|----------|
| D. Coupe | 03/25/14 | A. Leon | 03/25/14 |

Table of Contents

| | |
|----------------------------------|----------|
| 1. Before You Begin | 1 |
| What Is Included | 1 |
| Claims | 1 |
| Manual Conventions | 1 |
| Symbols | 1 |
| Product at a Glance | 2 |
| Safety Notes | 2 |
| Personal Safety..... | 2 |
| Mounting and Rigging | 2 |
| Power and Wiring..... | 2 |
| Operation | 2 |
| Expected LED Lifespan | 2 |
| 2. Introduction | 3 |
| Product Description | 3 |
| Features..... | 3 |
| Overview | 4 |
| Dimensions | 5 |
| 3. Setup | 6 |
| AC Power..... | 6 |
| AC Plug..... | 6 |
| Power Linking | 7 |
| DMX Linking..... | 7 |
| DMX Modes | 7 |
| Master/Slave Connectivity..... | 7 |
| Mounting | 8 |
| Orientation | 8 |
| Rigging..... | 8 |
| 4. Operation | 9 |
| Control Panel Description | 9 |
| Password | 9 |
| Control Options | 9 |
| Programming | 9 |
| DMX Personality | 10 |
| DMX Control..... | 10 |
| Loss of Signal Setting | 10 |
| Static Mode | 10 |
| Auto Programs | 11 |
| Edit Customs..... | 11 |
| Master/Slave Mode | 11 |
| Color Settings..... | 11 |
| Dimmer Curves | 12 |
| Curve Settings..... | 12 |
| Control Panel Lock..... | 12 |
| Password | 12 |
| Settings Lock Out..... | 12 |
| Program Upload..... | 13 |
| Reset..... | 13 |
| Calibration Settings Reset..... | 13 |
| Whites Setting..... | 14 |
| White Calibration..... | 14 |
| Strobe Personality | 14 |
| Menu Map | 15 |
| Menu Map (Continued) | 16 |



DMX Values 17
DMX Values (Continued) 18
DMX Values (Continued) 19
DMX Values (Continued) 20
DMX Values (Continued) 21

5. Technical Information 22

Product Maintenance 22
Returns 22
Technical Specifications 23
Contact Us 24

1. Before You Begin

- What Is Included**
- COLORado™ 1-TRI TOUR
 - powerCON® Power Cord
 - Gel Frame Holder (7.5 in/191 mm)
 - Safety Cable
 - Warranty Card
 - Quick Reference Guide

Claims Carefully unpack the product immediately and check the box to make sure all the parts are in the package and are in good condition.

If the box or the contents (the product and included accessories) appear damaged from shipping or show signs of mishandling, notify the carrier immediately, not CHAUVET®. Failure to report damage to the carrier immediately may invalidate your claim. In addition, keep the box and contents for inspection.

For other issues, such as missing components or parts, damage not related to shipping, or concealed damage, file a claim with CHAUVET® within 7 days of delivery.

Manual Conventions

| Convention | Meaning |
|-------------------------|--|
| 1~512 | A range of values in the text |
| 50/60 | A set of mutually exclusive values in the text |
| <SET> | A button on the product’s control panel |
| Settings | A product function or a menu option |
| MENU>Settings | A sequence of menu options |
| 1~10 | A range of menu values from which to choose in a menu |
| Yes/No | A set of two mutually exclusive menu options in a menu |
| ON | A unique value to be entered or selected in a menu |

Symbols

| Symbols | Meaning |
|---------|---|
| | Critical installation, configuration, or operation information. Failure to comply with this information may cause the product not to work, damage third-party equipment, or cause harm to the operator. |
| | Important installation or configuration information. Failure to comply with this information may keep the product from working. |
| | Useful information. |



The term “DMX” used throughout this manual refers to the USITT DMX512-A digital data transmission protocol.

| | | | | |
|----------------------------|-----------------|---|---------------------------|---|
| Product at a Glance | Use on Dimmer | X | Auto Programs | P |
| | Outdoor Use | P | Auto-Ranging Power Supply | P |
| | Sound-Activated | X | Replaceable Fuse | X |
| | DMX | P | User-Serviceable | X |
| | Master/Slave | P | | |

Safety Notes

Read all the following Safety Notes before working with this product. These notes include important information about the installation, usage, and maintenance of this product.



This product contains no user-serviceable parts. Any reference to servicing in this User Manual applies to properly trained CHAUVET® certified technicians. Do not open the housing or attempt any repairs.



All applicable local codes and regulations apply to the proper installation of this product.

Personal Safety

- Avoid direct eye exposure to the light source while the product is on.
- Always disconnect this product from its power source before servicing.
- Always connect this product to a grounded circuit to avoid the risk of electrocution.
- Do not touch this product's housing during operation because it may be very hot.
- This product is for indoor use only! To prevent risk of fire or shock, do not expose this product to rain or moisture.
- Make sure there are no flammable materials close to this product while it is operating.
- When hanging this product, always secure to a fastening device using a safety cable (included).

Mounting and Rigging

Power and Wiring

- Always make sure you are connecting this product to the proper voltage in accordance with the specifications in this manual or on the product's specification label.
- Never connect this product to a dimmer pack or rheostat.
- Never disconnect this product by pulling or tugging on the power cable.
- Do not operate this product if you see damage on the housing, lenses, or cables. Have the damaged parts replaced by an authorized technician at once.
- Do not cover the ventilation slots when operating to avoid internal overheating.
- The maximum ambient temperature is 113 °F (45 °C). Do not operate this product at a higher temperature.
- In case of a serious operating problem, stop using this product immediately!

Operation



Expected LED Lifespan

In the unlikely event that your CHAUVET® product may require service, contact CHAUVET® Technical Support.

LEDs gradually decline in brightness over time, mostly because of heat. Packaged in clusters, LEDs exhibit higher operating temperatures than in ideal, single-LED conditions. For this reason, using clustered LEDs at their fullest intensity significantly reduces the LEDs' lifespan. Under normal conditions, this lifespan can be 40,000 to 50,000 hours. If extending this lifespan is vital, lower the operating temperature by improving the ventilation around the product and reducing the ambient temperature to an optimal operating range. In addition, limiting the overall projection intensity may also help to extend the LEDs' lifespan.

2. Introduction

Product Description

The COLORado™ 1-TRI TOUR is an RGB wash product based on 14 tri-color (RGB) LEDs. It consists of a single pod with a double-bracket mounting yoke. The AC power comes directly into the fixture's housing through a Neutrik® powerCON A socket. The power linking uses a Neutrik® powerCON B socket. The DMX input and output sockets are of the 3-pin and 5-pin XLR type. The COLORado™ 1-Tri Tour uses a display-based control panel for programming functions.

Features

- 3-, 4-, 5-, 9-, or 13-channel tri-color LED wash product
- Operating modes:
 - 3-channel: HSV control
 - 3-channel: RGB control
 - 4-channel: RGB, dimmer
 - 5-channel: RGB, dimmer, strobe
 - 9-channel: RGB, dimmer, macro, strobe, auto/custom, auto speed, dimmer speed
 - 13-channel: RGB, dimmer, strobe, macro, auto/custom, dimmer speed, auto speed
- RGB color mixing with or without DMX control
- IP20-rated

Overview

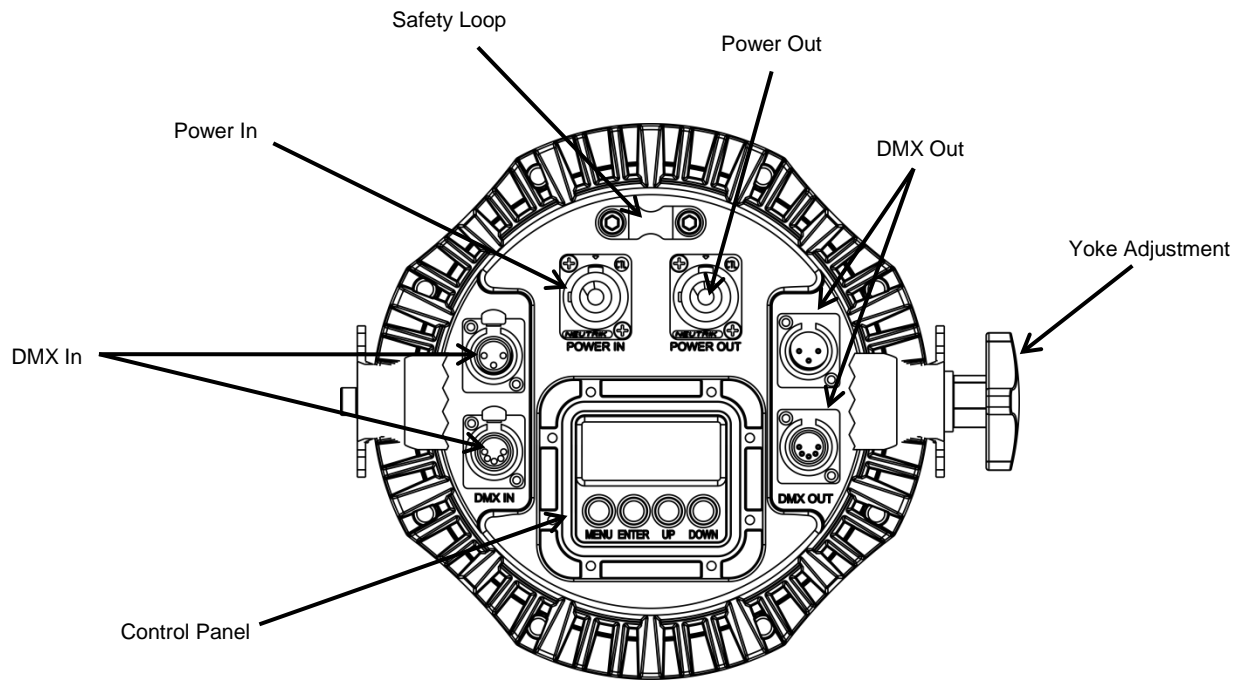

Rear View

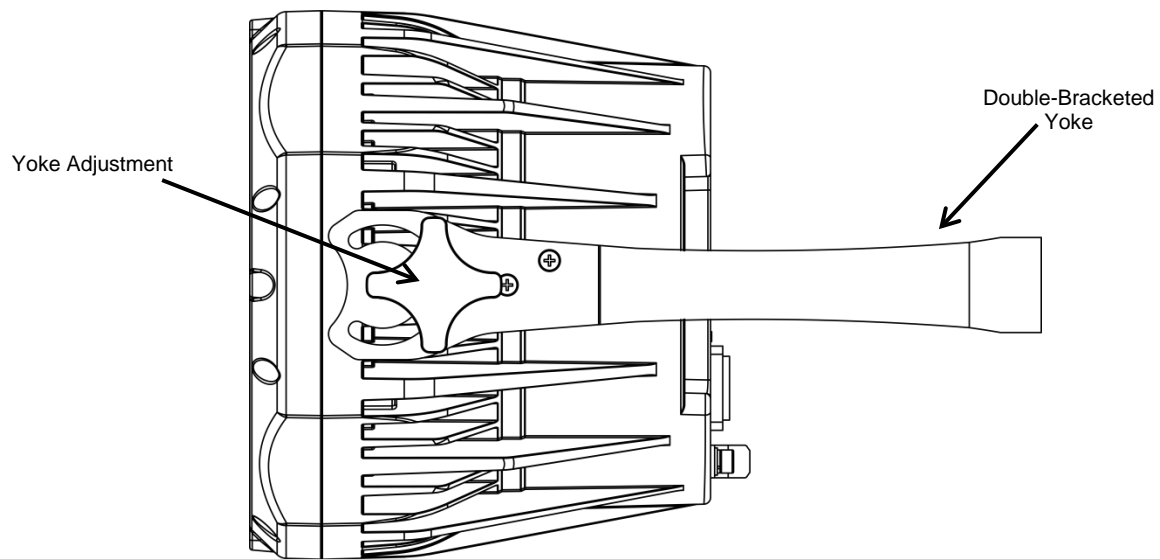

Side View

Dimensions

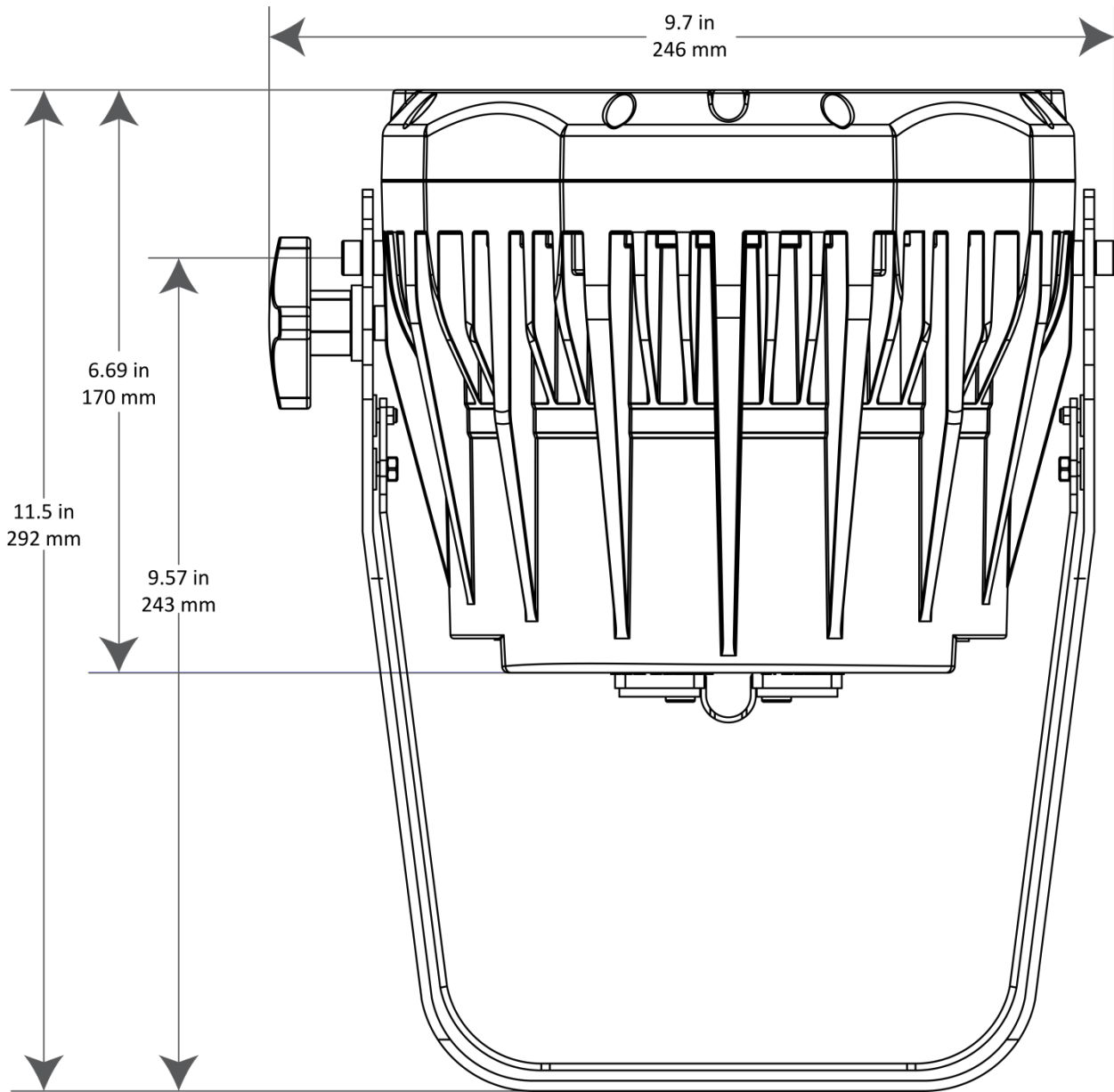

Side View

3. Setup

AC Power

Each COLORado™ 1-TRI TOUR has an auto-ranging power supply that works with an input voltage range of 100~240 VAC, 50/60 Hz. To determine the power requirements for each COLORado™ 1-TRI TOUR, refer to the label affixed to the product. You can also refer to the [Technical Specifications](#) in this manual.

The listed current rating indicates the maximum current draw during normal operation. For more information, you may download Sizing Circuit Breakers from the CHAUVET® website: www.chauvetpro.com.



Always connect this product to a protected circuit with an appropriate electrical ground to avoid the risk of electrocution or fire.



Never connect this product to a rheostat (variable resistor) or dimmer circuit, even if the rheostat or dimmer channel serves only as a 0 to 100% switch.

AC Plug

The COLORado™ 1-TRI TOUR comes with a NEUTRIK® powerCON A connector on one end and an Edison plug on the other end (US market). If the power cord adapter that came with your product has no plug or you need to change the Edison plug, use the table below to wire the new plug.

| Connection | Wire (U.S.) | Wire (Europe) | Screw Color |
|------------|--------------|---------------|-----------------|
| AC Live | Black | Brown | Yellow or Brass |
| AC Neutral | White | Blue | Silver |
| AC Ground | Green/Yellow | Green/Yellow | Green |

Power Linking

The COLORado™ 1-TRI TOUR supports power linking. You can power link up to 18 products at 120 VAC, 31 products at 208 VAC, or 34 products at 230 VAC.

This product comes with a power input cord. This product does not come with a power linking cable; however, a power linking cable is available as an option.

DMX Linking

You can link the COLORado™ 1-TRI TOUR to a DMX controller using a standard DMX serial connection. If using other DMX-compatible products with the COLORado™ 1-TRI TOUR, you can control each individually with a single DMX controller.

DMX Modes

The COLORado™ 1-TRI TOUR uses a regular DMX data connection for the **TOUR**, **TR16.**, **ARC.1**, **AR1.d**, **AR1.S**, and **HSV**. channel DMX modes.

- Refer to the [Introduction](#) for a brief description of these modes.
- Refer to [Operation](#) to learn how to configure the COLORado™ 1-TRI TOUR to work in these modes.
- The [DMX Values](#) section will provide you with detailed information regarding the DMX modes.

Master/Slave Connectivity

The Master/Slave mode allows a COLORado™ 1-TRI TOUR (the “master product”) to control one or more COLORado™ 1-TRI TOURs (the “slave products”) without a DMX controller. One COLORado™ 1-TRI TOUR becomes the master product when running an Auto or Custom program, or by being in Static mode.

You must configure each slave product’s control panel to operate in Slave mode. During Master/Slave operation, the slave products will operate in unison with the master product.



DO NOT connect a DMX controller to products operating in Master/Slave mode. The DMX controller signals may interfere with the signals from the master product.



The [Operation](#) section of this manual provides detailed instructions on how to configure Master and Slave products.



Note: For optimum control of the 16-bit dimming channels in the TR16. personality, be sure that both dimming curves in SET > DIMX and SET > CURV are set to OFF.



If you are not familiar with or need more information about DMX standards, Master/Slave connectivity, or the DMX cables needed to link this product to a DMX controller, download the DMX Primer from the CHAUVET® website: www.chauvetpro.com.

- Mounting** Before mounting this product, read and follow the [Safety Notes](#) in this manual.
- Orientation** Always mount this product in a safe position and make sure there is adequate room for ventilation, configuration, and maintenance.
- Rigging** The COLORado™ 1-TRI TOUR consists of a double-bracketed yoke and the body of the product. CHAUVET® recommends using the following general guidelines when mounting this product.
- When selecting an installation location, consider easy access to this product for operation, programming adjustments, and routine maintenance.
 - Make sure to mount this product away from any flammable material as indicated in the [Safety Notes](#).
 - Never mount in places where rain, high humidity, extreme temperature changes, or restricted ventilation may affect the product.
 - If hanging this product, make sure that the mounting location can support the product's weight. Refer to the [Technical Specifications](#) for the weight-bearing requirements of this product.
 - When hanging this product, always secure to a fastening device using a safety cable (included).
- Procedure** The COLORado™ 1-TRI TOUR comes with a multi-purpose yoke to which you can either attach mounting clamps for hanging, or attach to the floor for use as a floor stand. You must supply your own mounting clamps. Make sure the clamps are capable of supporting the weight of this product.

Diagram

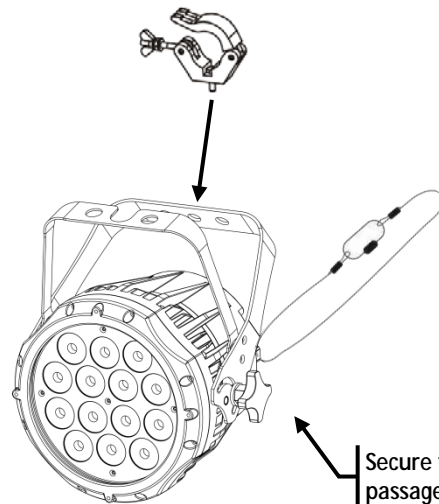

Overhead Mounting

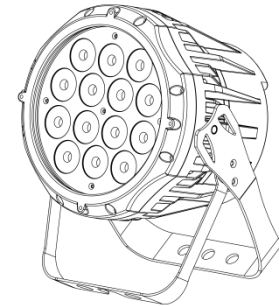

Floor Mounting

Secure the safety cable using the passageway on the back of the fixture.

4. Operation

Control Panel Description

| Button | Function |
|---------|--|
| <MENU> | Exits from the current menu or function |
| <ENTER> | Enables the currently displayed menu or sets the currently selected value in to the current function |
| <UP> | Navigates upward through the menu list and increases the numeric value when in a function |
| <DOWN> | Navigates downward through the menu list and decreases the numeric value when in a function |

Password

After being prompted, enter the following password by pressing:

<UP>, <DOWN>, <UP>, <DOWN>, <ENTER>

This password cannot be changed and must be used whenever prompted.

Control Options

You can set the COLORado™ 1-TRI TOUR start address in the 001~512 DMX range. This enables control of up to 32 products in the 13-channel **TR16**. personality.

Programming

Refer to the [Menu Map](#) to understand the menu options. The menu map shows the main level and a variable number of programming levels for each option.

- To go to the desired main level, press <MENU> repeatedly until the option shows on the display. Press <ENTER> to select. This will take you to the first programming level for that option.
- To select an option or value within the current programming level, press <UP> or <DOWN> until the option shows on the display. Press <ENTER> to select. In this case, if there is another programming level, you will see that first option, or you will see the selected value.
- Press <MENU> repeatedly to exit to the previous main level.

DMX Personality This setting allows you to choose a particular DMX personality.

1. Go to the **PERS** main level.
 2. Select the desired personality (**TOUR**, **TR16.**, **ARC.1**, **AR1.d**, **AR1.S**, **HSV.**).
- **See the DMX Values section for the highest starting address you can select for each personality.**
 - **Make sure that the starting addresses on the various products do not overlap due to the new personality setting.**



DMX Control In this mode, each product will respond to a unique starting address from the DMX controller. All products with the same starting address will respond in unison.

1. Select a DMX personality as shown in [DMX Personality](#).
2. Set the running mode:
 - a. Go to the **RUN** main level.
 - b. Select the **dMX**. programming level.
3. Set the starting address:
 - a. Go to **dMX** main level.
 - b. Select the starting address **d.(001~512)**.

The highest recommended starting address for each DMX mode is as follows:



| DMX Mode | DMX Address | DMX Mode | DMX Address | DMX Mode | DMX Address |
|--------------|-------------|--------------|-------------|--------------|-------------|
| TOUR | 504 | ARC.1 | 510 | AR1.S | 508 |
| TR16. | 500 | AR1.d | 509 | HSV | 510 |

Loss of Signal Setting This setting controls how the product will respond when the DMX signal is lost.

1. Go to the **SET** main level, and select **DERR**.
 - a. Select **SAVE**. to make the product use the last command used when the signal is lost.
 - b. Select **BLAK**. to turn off the all the LEDs when the signal is lost.

Static Mode The Static mode allows the mixing of RGB colors and the setting of the strobe frequency without a DMX controller.

1. Go to the **STAT** main level.
2. Select the desired color: **R.** (red), **G.** (green), **b.** (blue).
3. Select the desired color value (**000~255**).
4. Repeat for the other colors.
5. Select **ST.** (strobe frequency).
6. Select the desired strobe frequency **00~20** (0~20 Hz).

Auto Programs Auto programs allow for dynamic RGB color mixing without a DMX controller.

1. Go to **AUTO**.
2. Select the desired auto (**AT.01~10**) or custom program (**PR.01~10**).



You cannot edit any of the auto programs (AT.01~10); however, you can edit the custom programs (PR.01~10). See Edit Customs below for details.

Edit Customs

This setting allows the programming of up to 30 scenes for each of the 10 customizable programs, including colors and effects.

1. Go to the **EdIT** main level.
2. Select the desired auto program (**PR.01~10**).
3. Select the desired scene (**SC.01~30**).
4. Select the desired color or effect: **R.** (red), **G.** (green), **b.** (blue), **Sb.** (strobe frequency), **T.** (step duration), **F.** (fade duration).
5. Select the color or effect value (**000~255** for colors and timers, or **00~20** for strobe).
6. Repeat for the other colors or effects.
7. Return to the scene (**SC.01~30**) level.
8. Repeat the settings of colors and effects for the other scenes.

Master/Slave Mode

The Master/Slave mode allows a group of COLORado™ 1-TRI TOURs (the slave products) to simultaneously duplicate the output of another COLORado™ 1-TRI TOUR (the master product) without a DMX controller.

1. Set each of the slave products:
 - a. Go to **RUN**.
 - b. Select **SLAV**.
2. Set the master product:
 - a. Set the running mode to **dmx**, as explained in [DMX Control](#).
 - b. Select an auto or custom program as explained in Auto Programs above, or a static mix of colors.

- **The master product is the one that runs a program whether in Auto, Custom or Static mode.**
- **Do not connect a DMX controller to the products configured for Master/Slave operation. The DMX controller may interfere with signals from the master product.**
- **The master product should be the first product in the daisy chain.**



Color Settings

The Color setting determines how the COLORado™ 1-TRI TOUR generates the white color based on various RGB settings.

1. Go to the **SET** main level.
2. Select **COLO**.
3. Select **OFF**, **RGBw.**, or **UC**.

OFF: When all the RGB faders are set to **255**, the output is maximum, although the resulting white color may not be balanced.



RGBw.: When all the RGB faders are set to **255**, the resulting output is defined by the configured white color (balanced white). See [White Calibration](#).

UC.: When all the RGB faders are set to **255**, the output matches that of less efficient products (universal color balance).

Dimmer Curves This setting determines how fast the output of the COLORado™ 1-TRI TOUR changes when you modify the values of the red, green, blue, and dimmer faders. This setting provides four different options to simulate the dimming speed of an incandescent lighting product.

1. Go to the **SET** main level.
2. Select **dIM..**
3. Select a dimmer curve (**OFF.**, **dIM1.**, **dIM2.**, **dIM3.**, or **dIM4.**).



OFF.: The output is proportional (linear) to the dimmer and RGB channel values.
dIM1.-dIM4.: The output follows the dimmer and RGB channel values based on the corresponding dimmer speed, **dIM1.** being the fastest and **dIM4.** being the slowest.

Curve Settings This setting determines the shape of the output curve of the COLORado™ 1-TRI TOUR when you modify the values of the red, green, blue, and dimmer faders. This setting provides three different options to simulate the dimming curve of an incandescent lighting product.

1. Go to the **SET** main level.
2. Select **CURV..**
3. Select a dimmer curve (**OFF.**, **CV1.**, **CV2.**, or **CV3.**).



OFF.: This output is proportional (linear) to the dimmer and RGB channel values.
CV1.-CV3.: This output follows the dimmer and RGB channel values based on the corresponding dimmer curve, **CV1.** being the fastest and **CV3.** being the slowest.

Control Panel Lock This setting enables you to activate or disable the control panel lock, which keeps unauthorized personnel from changing the product's settings.

1. Go to the **KEY** main level.
2. Select **ON** or **OFF**.



When the control panel lock is active, the product will prompt you to enter the password after 30 seconds of control panel inactivity or after turning on the product.

Password After being prompted to enter the password:

- Press **<UP>**, **<DOWN>**, **<UP>**, **<DOWN>**, **<ENTER>**.

Settings Lock Out This setting enables you to activate or disable the main level **SET** (settings) lock, which keeps unauthorized personnel from changing the product's settings.

1. Go to the **SET** main level.
2. Select **SLCK..**
3. Select **ON.** or **OFF..**

Program Upload This option allows you to copy the custom programs of one COLORado™ 1-TRI TOUR onto other COLORado™ 1-TRI TOURs by using the Master/Slave mode.

1. Configure and connect the products in a Master/Slave arrangement, where the master product has the custom programs you want to transfer to the slave products.
2. From the master product, go to the **SET** main level.
3. Select **UPLd.**
4. When **PASS** shows, press **<ENTER>**.
5. Enter the master access password as shown in [Control Panel Lock](#).
6. When **SEND** shows, press **<ENTER>** to start the upload.
7. Wait for the upload process to finish (the display will show **END** before continuing or turning the products off).

The Master/Slave products will provide the status of the process by lighting up as follows:



- **Yellow indicates that the upload process is running.**
- **Green indicates that the upload process completed successfully.**
- **Red indicates that the upload process failed due to an error. Recheck all cable connections and restart the process. If the issue persists, contact CHAUVET® Technical Support.**



DO NOT upload the data from a COLORado™ 1-TRI TOUR to a different product. The other product may become inoperable.

Reset

This setting allows you to reset the COLORado™ 1-TRI TOUR to the default values, including the custom programs.

1. Go to the **SET** main level.
2. Select **REST.**
3. When **PASS** shows, press **<ENTER>**.
4. Enter the master access password as described in [Control Panel Lock](#).
5. Wait for the reset process to finish.

Calibration Settings Reset

This setting allows you to reset the COLORado™ 1-TRI TOUR to the default values of the color macros in [Whites Setting](#) or [Whites Calibration](#).

1. Go to the **CAL** main level.
2. When **PASS** shows, press **<ENTER>**.
3. Enter the master access password as described in [Control Panel Lock](#).
4. Go to **CALR**.
5. When **PASS** shows, press **<ENTER>**.
6. Enter the master access password as described in [Control Panel Lock](#).
7. Go to **CALR**.
8. Go to **OK**.

- Whites Setting** This setting allows you to select and edit the temperature of the white colors used in channel 5 (Macros) when in the **TOUR** mode or channel 9 in **TR16**. mode.
1. Go to the **CAL** main level.
 2. Enter the master access password as described in [Control Panel Lock](#)
 3. Go to **CAL1**.
 4. Select a white color (**wT.01~11**).
 5. Select a color: **R.** (red), **G.** (green), **b.** (blue).
 6. Select a color value (**000~255**).
 7. Repeat for the other colors.

- White Calibration** This setting allows you to select the white color shown by the COLORado™ 1-TRI TOUR when the color setting is **RGBw.** and the DMX controller's red, green, and blue faders are set to **255**.
1. Go to the **CAL** main level.
 2. Enter the master access password as described in [Control Panel Lock](#)
 3. Go to **CAL2**.
 4. Go to **RGBw..**
 5. Select a color: **R.** (red), **G.** (green), **b.** (blue).
 6. Select a color value (**000~255**).
 7. Repeat for the other colors.



When selecting CAL > CAL2 > RGBw., you will only be able to define the values of R. (red), G. (green), and b. (blue).



The values of R. (red), G. (green), and b. (blue) configured from CAL > CAL2 > RGBw. will define the color temperature shown when the RGB faders are set to "255" if SET > COLO. > RGBw. is active.

- Strobe Personality** This setting allows you to select the classic strobe (01~20 Hz) or special (random/slow/fast) strobe personalities.
1. Go to the **SET** main level.
 2. Go to **STRB..**
 3. Select a strobe personality (**CLAS.** or **SPEC.**).

Menu Map

| Main Level | Programming Levels | | | | Description | | |
|------------|--------------------|---------|-----|-------|---|---------|---|
| STAT | R. | 000~255 | | | Combines red, green, and blue to make a custom color | | |
| | G. | | | | | | |
| | b. | | | | | | |
| | ST. | 00~20 | | | Selects the strobe frequency (0~20 Hz) | | |
| AUTO | AT. | 01~10 | | | 10 automatic programs | | |
| | PR. | | | | 10 customizable programs | | |
| RUN | dMX. | | | | DMX mode | | |
| | SLAV | | | | Master/Slave mode | | |
| dMX | d. | 001~512 | | | Selects the DMX starting address | | |
| PERS | TOUR | | | | 9 Channels: R/G/B, dimmer, strobe, color macro, auto/custom, dimmer speed, auto speed | | |
| | TR16. | | | | 13 Channels: 16-bit R/G/B, dimmer, strobe, color macro, auto/custom, dimmer speed, auto speed | | |
| | ARC.1 | | | | 3-channel: R/G/B control | | |
| | AR1.d | | | | 4-channel: R/G/B, dimmer | | |
| | AR1.S | | | | 5-channel: R/G/B, dimmer, strobe | | |
| | HSV. | | | | 3-channel: HSV control | | |
| EdIT | PR. | 01~10 | SC. | 01~30 | R. | 000~255 | Combines red, green, and blue to generate a custom color (0~100%) |
| | | | | | G. | | |
| | | | | | b. | | |
| | | | | | Sb. | 00~20 | Selects the strobe frequency (0~20 Hz) |
| | | | | | T. | 000~255 | Defines the step duration (0~100%) |
| | | | | | F. | | Defines the fade duration (0~100%) |

Menu Map (Continued)

| Main Level | Programming Levels | | | | Description | |
|------------|--------------------|--------------------------|---|---|--|--|
| SET | UPLd. | (Enter Passcode) | | | Uploads custom programs to other COLORado™ 1-TRI TOURs | |
| | REST. | (Enter Passcode) | | | Defaults product to factory settings | |
| | COLO. | OFF | | | RGB set to 255 = max. output | |
| | | RGBw. | | | RGB set to 255 = balanced white | |
| | | UC. | | | Universal color balance | |
| | DIM. | OFF. | | | No dimmer | |
| | | dIM1. | | | Dimmer curve | |
| | | dIM2. | | | | |
| | | dIM3. | | | | |
| | dIM4. | | | | | |
| | CURV. | OFF. | | | No dimmer | |
| | | CV1. | | | Slow (CV3.) to fast (CV1.) dimmer curves | |
| | | CV2. | | | | |
| | | CV3. | | | | |
| | DERR. | | | SAVE. | | Continues with last command upon loss of DMX control |
| | SLCK. | BLAK. | | | Blacks out fixture upon loss of DMX | |
| | | OFF. | | | SET main level access lock | |
| | STRB. | ON. | | | | |
| SPEC. | | | Selects strobe personality used in TOUR and TR16. personalities | | | |
| CAL | CAL1 | wT. | 01~11 | R. | 000~255 | Modifies the color macros used in the TOUR and TR16. personalities |
| | | | | G. | | |
| | | | | b. | | |
| | CAL2 | RGBw. | R. | Defines the color temperature used when COLO. is set to RGBw. | | |
| | | | G. | | | |
| | CALR | (Enter Passcode) | CALR | OK | | Defaults CAL to factory settings |
| KEY | | | | | | |
| ON | | | | Turns the password on or off | | |
| OFF | | | | | | |

DMX Values

| TOUR | Channel | Function | Value | Percent/Setting |
|------|----------------|--------------------------------|-----------|---|
| | 1 | Dimmer | 000 ó 255 | 0~100% |
| | 2 | Red | 000 ó 255 | 000~255 (Step Time if Auto 1~10 active) |
| | 3 | Green | 000 ó 255 | 000~255 (Fade Time if Auto 1~10 active) |
| | 4 | Blue | 000 ó 255 | 0~100% |
| | 5 | Color Macro + White Balance | 000 ó 010 | No Function |
| | | | 011 ó 030 | R: 100% G: 0~100% B: 0 |
| | | | 031 ó 050 | R: 100%~0 G: 100% B: 0 |
| | | | 051 ó 070 | R: 0 G: 100% B: 0~100% |
| | | | 071 ó 090 | R: 0 G: 100%~0 B: 100% |
| | | | 091 ó 110 | R: 0~100% G: 0 B: 100% |
| | | | 111 ó 130 | R: 100% G: 0 B: 100%~0 |
| | | | 131 ó 150 | R: 100% G: 0~100% B: 0~100% |
| | | | 151 ó 170 | R: 100%~0 G: 100%~0 B: 100% |
| | | | 171 ó 200 | R: 100% G: 100% B: 100% |
| | | | 201 ó 205 | White 1 |
| | | | 206 ó 210 | White 2 |
| | | | 211 ó 215 | White 3 |
| | | | 216 ó 220 | White 4 |
| | | | 221 ó 225 | White 5 |
| | | | 226 ó 230 | White 6 |
| | | | 231 ó 235 | White 7 |
| | 236 ó 240 | White 8 | | |
| | 241 ó 245 | White 9 | | |
| | 246 ó 250 | White 10 | | |
| | 251 ó 255 | White 11 | | |
| | Special Strobe | | 000 ó 010 | No Function |
| | | | 011 ó 099 | Slow to Fast |
| | | | 100 ó 109 | No Function |
| | | | 110 ó 179 | Lighting Effect Slow to Fast |
| | | | 180 ó 189 | No Function |
| | 190 ó 255 | Random | | |
| | 6* | Classic Strobe | 000 ó 010 | No Function |
| | | | 011 ó 019 | 1 Hz |
| | | | 020 ó 029 | 2 Hz |
| | | | 030 ó 039 | 3 Hz |
| | | | 040 ó 049 | 4 Hz |
| | | | 050 ó 059 | 5 Hz |
| | | | 060 ó 069 | 6 Hz |
| | | | 070 ó 079 | 7 Hz |
| | | | 080 ó 089 | 8 Hz |
| | | | 090 ó 099 | 9 Hz |
| | | | 100 ó 109 | 10 Hz |
| | | | 110 ó 119 | 11 Hz |
| | | | 120 ó 129 | 12 Hz |
| | | | 130 ó 139 | 13 Hz |
| | | | 140 ó 149 | 14 Hz |
| | | | 150 ó 159 | 15 Hz |
| | 160 ó 169 | 16 Hz | | |
| | 170 ó 179 | 17 Hz | | |
| | 180 ó 189 | 18 Hz | | |
| | 190 ó 199 | 19 Hz | | |
| | 200 ó 255 | 20 Hz | | |

*Select strobe function in the main menu under **SET > STRB. > CLAS. or SPEC.**

DMX Values (Continued)

| TOUR (Cont.) | Channel | Function | Value | Percent/Setting |
|-----------------|---------|--------------|-----------|---------------------------------------|
| | 7 | Programs | 000 ó 020 | No Function |
| | | | 021 ó 030 | Auto 1 |
| | | | 031 ó 040 | Auto 2 |
| | | | 041 ó 050 | Auto 3 |
| | | | 051 ó 060 | Auto 4 |
| | | | 061 ó 070 | Auto 5 |
| | | | 071 ó 080 | Auto 6 |
| | | | 081 ó 090 | Auto 7 |
| | | | 091 ó 100 | Auto 8 |
| | | | 101 ó 110 | Auto 9 |
| | | | 111 ó 120 | Auto 10 |
| | | | 121 ó 130 | Custom 1 |
| | | | 131 ó 140 | Custom 2 |
| | | | 141 ó 150 | Custom 3 |
| | | | 151 ó 160 | Custom 4 |
| | | | 161 ó 170 | Custom 5 |
| | | | 171 ó 180 | Custom 6 |
| | | | 181 ó 190 | Custom 7 |
| | | | 191 ó 200 | Custom 8 |
| | | | 201 ó 210 | Custom 9 |
| | | | 211 ó 220 | Custom 10 |
| | | | 221 ó 255 | No Function |
| | 8 | Auto Speed | 000 ó 255 | 0~100% (only when using Auto 1~10) |
| | 9 | Dimmer Speed | 000 ó 009 | Preset dimmer speed from display menu |
| | | | 010 ó 029 | Linear dimmer |
| | | | 030 ó 069 | Nonlinear dimming curve 1 (fastest) |
| | | | 070 ó 129 | Nonlinear dimming curve 2 |
| | | | 130 ó 189 | Nonlinear dimming curve 3 |
| | | | 190 ó 255 | Nonlinear dimming curve 4 (slowest) |

DMX Values (Continued)

| TR16. | Channel | Function | Value | Percent/Setting |
|-------|-----------|--------------------------------|-----------|---|
| | 1 | Dimmer | 000 ó 255 | 0~100% |
| | 2 | Fine Dimmer | 000 ó 255 | 0~100% |
| | 3 | Red | 000 ó 255 | 000~255 (Step Time if Auto 1~10 active) |
| | 4 | Fine Red | 000 ó 255 | 000~255 (Fade Time if Auto 1~10 active) |
| | 5 | Green | 000 ó 255 | 0~100% |
| | 6 | Fine Green | 000 ó 255 | 0~100% |
| | 7 | Blue | 000 ó 255 | 0~100% |
| | 8 | Fine Blue | 000 ó 255 | 0~100% |
| | 9 | Color Macro + White Balance | 000 ó 010 | No Function |
| | | | 011 ó 030 | R: 100% G: 0~100% B: 0 |
| | | | 031 ó 050 | R: 100%~0 G: 100% B: 0 |
| | | | 051 ó 070 | R: 0 G: 100% B: 0~100% |
| | | | 071 ó 090 | R: 0 G: 100%~0 B: 100% |
| | | | 091 ó 110 | R: 0~100% G: 0 B: 100% |
| | | | 111 ó 130 | R: 100% G: 0 B: 100%~0 |
| | | | 131 ó 150 | R: 100% G: 0~100% B: 0~100% |
| | | | 151 ó 170 | R: 100%~0 G: 100%~0 B: 100% |
| | | | 171 ó 200 | R: 100% G: 100% B: 100% |
| | | | 201 ó 205 | White 1 |
| | | | 206 ó 210 | White 2 |
| | | | 211 ó 215 | White 3 |
| | | | 216 ó 220 | White 4 |
| | | | 221 ó 225 | White 5 |
| | | | 226 ó 230 | White 6 |
| | | | 231 ó 235 | White 7 |
| | 236 ó 240 | White 8 | | |
| | 241 ó 245 | White 9 | | |
| | 246 ó 250 | White 10 | | |
| | 251 ó 255 | White 11 | | |

DMX Values (Continued)

| TR16. (Cont.) | Channel | Function | Value | Percent/Setting |
|------------------|----------------|-------------|-----------|------------------------------|
| 10* | Special Strobe | | 000 ó 010 | No Function |
| | | | 011 ó 099 | Slow to Fast |
| | | | 100 ó 109 | No Function |
| | | | 110 ó 179 | Lighting Effect Slow to Fast |
| | | | 180 ó 189 | No Function |
| | | | 190 ó 255 | Random |
| | Classic Strobe | | 000 ó 010 | No Function |
| | | | 011 ó 019 | 1 Hz |
| | | | 020 ó 029 | 2 Hz |
| | | | 030 ó 039 | 3 Hz |
| | | | 040 ó 049 | 4 Hz |
| | | | 050 ó 059 | 5 Hz |
| | | | 060 ó 069 | 6 Hz |
| | | | 070 ó 079 | 7 Hz |
| | | | 080 ó 089 | 8 Hz |
| | | | 090 ó 099 | 9 Hz |
| | | | 100 ó 109 | 10 Hz |
| | | | 110 ó 119 | 11 Hz |
| | | | 120 ó 129 | 12 Hz |
| | | | 130 ó 139 | 13 Hz |
| | | 140 ó 149 | 14 Hz | |
| | 150 ó 159 | 15 Hz | | |
| | 160 ó 169 | 16 Hz | | |
| | 170 ó 179 | 17 Hz | | |
| | 180 ó 189 | 18 Hz | | |
| | 190 ó 199 | 19 Hz | | |
| | 200 ó 255 | 20 Hz | | |
| 11 | Programs | | 000 ó 020 | No Function |
| | | | 021 ó 030 | Auto 1 |
| | | | 031 ó 040 | Auto 2 |
| | | | 041 ó 050 | Auto 3 |
| | | | 051 ó 060 | Auto 4 |
| | | | 061 ó 070 | Auto 5 |
| | | | 071 ó 080 | Auto 6 |
| | | | 081 ó 090 | Auto 7 |
| | | | 091 ó 100 | Auto 8 |
| | | | 101 ó 110 | Auto 9 |
| | | | 111 ó 120 | Auto 10 |
| | | | 121 ó 130 | Custom 1 |
| | | | 131 ó 140 | Custom 2 |
| | | | 141 ó 150 | Custom 3 |
| | | | 151 ó 160 | Custom 4 |
| | | | 161 ó 170 | Custom 5 |
| | | | 171 ó 180 | Custom 6 |
| | | | 181 ó 190 | Custom 7 |
| | | | 191 ó 200 | Custom 8 |
| | | | 201 ó 210 | Custom 9 |
| | 211 ó 220 | Custom 10 | | |
| | 221 ó 255 | No Function | | |

*Select strobe function in the main menu under **SET > STRB. > CLAS. or SPEC.**

DMX Values (Continued)

| | | | | |
|--------------------------|----------------|-----------------|-------------------------------------|---------------------------------------|
| TR16. (Cont.) | Channel | Function | Value | Percent/Setting |
| | 12 | Auto Speed | 000 ó 255 | 0~100% (Only when using Auto 1~10) |
| | 13 | Dimmer Speed | 000 ó 009 | Preset dimmer speed from display menu |
| | | | 010 ó 029 | Linear dimmer |
| | | | 030 ó 069 | Nonlinear dimming curve 1 (fastest) |
| 070 ó 129 | | | Nonlinear dimming curve 2 | |
| | | 130 ó 189 | Nonlinear dimming curve 3 | |
| | | 190 ó 255 | Nonlinear dimming curve 4 (slowest) | |
| ARC.1 | Channel | Function | Value | Percent/Setting |
| | 1 | Red | 000 ó 255 | 0~100% |
| | 2 | Green | 000 ó 255 | 0~100% |
| | 3 | Blue | 000 ó 255 | 0~100% |
| AR1.d | Channel | Function | Value | Percent/Setting |
| | 1 | Dimmer | 000 ó 255 | 0~100% |
| | 2 | Red | 000 ó 255 | 0~100% |
| | 3 | Green | 000 ó 255 | 0~100% |
| | 4 | Blue | 000 ó 255 | 0~100% |
| AR1.S | Channel | Function | Value | Percent/Setting |
| | 1 | Dimmer | 000 ó 255 | 0~100% |
| | 2 | Red | 000 ó 255 | 0~100% |
| | 3 | Green | 000 ó 255 | 0~100% |
| | 4 | Blue | 000 ó 255 | 0~100% |
| | 5 | Strobe | 000 ó 255 | 0~20 Hz |
| HSV. | Channel | Function | Value | Percent/Setting |
| | 1 | Hue | 000 ó 255 | 0~100% |
| | 2 | Saturation | 000 ó 255 | 0~100% |
| | 3 | Value | 000 ó 255 | 0~100% |

5. Technical Information

Product Maintenance

To maintain optimum performance and minimize wear, you should clean this product frequently. Usage and environment are contributing factors in determining the cleaning frequency.

As a rule, clean this product at least twice a month. Dust build-up reduces light output performance and can cause overheating. This can lead to reduced light source life and increased mechanical wear.

To clean your product:

- Unplug the product from power.
- Wait until the product is at room temperature.
- Use a vacuum (or dry compressed air) and a soft brush to remove dust collected on the external surfaces.
- Clean all external surfaces with a mild solution of non-ammonia glass cleaner or isopropyl alcohol.
- Apply the solution directly to a soft, lint-free cotton cloth or a lens cleaning tissue.
- Wipe any dirt or grime to the outside edges of the lens surface.
- Gently polish the lens surfaces until they are free of haze and lint.



Always dry the external surfaces thoroughly and carefully after cleaning them.

Returns

You must send the product prepaid, in the original box, and with the original packing and accessories. CHAUVET® will not issue call tags.

Call CHAUVET® and request a Return Merchandise Authorization (RMA) number before shipping the product. Be prepared to provide the model number, serial number, and a brief description of the cause(s) for the return.

Clearly label the package with an RMA number. CHAUVET® will refuse any product returned without an RMA number.



DO NOT write the RMA number directly on the box. Instead, write it on a properly affixed label.

Once you have received the RMA number, include the following information on a piece of paper inside the box:

- Your name
- Your address
- Your phone number
- RMA number
- A brief description of the problem(s)

Be sure to pack the product properly. Any shipping damage resulting from inadequate packaging will be the customer's responsibility. FedEx packing and double-boxing are recommended.



CHAUVET® reserves the right to use its own discretion to repair or replace returned product(s).

Technical Specifications

| Dimensions and Weight | Length | Width | Height | Weight |
|-----------------------|---------------|-----------------|------------------|---------------|
| | 8 in (202 mm) | 9.7 in (246 mm) | 11.5 in (292 mm) | 8.8 lb (4 kg) |

Note: Dimensions in inches rounded to the nearest decimal digit.

| Electrical | Power Supply Type | Range | Voltage Selection |
|------------|----------------------|---------------------|-------------------|
| | Switching (internal) | 100~240 V, 50/60 Hz | Auto-ranging |

| Parameter | 120 V, 60 Hz | 230 V, 50 Hz |
|-------------------|--------------|--------------|
| Consumption | 87 W | 93 W |
| Operating current | 0.73 A | 0.4 A |
| Power linking | 18 products | 34 products |

| Power I/O | U.S./Worldwide | Europe |
|------------------------|----------------------|----------------------|
| Power input connector | Neutrik® powerCON® A | Neutrik® powerCON® A |
| Power output connector | Neutrik® powerCON® B | Neutrik® powerCON® B |
| Power cord plug | Edison (U.S.) | Local plug |

| Light Source | Type | Power | Lifespan |
|--------------|------|-------|--------------|
| | LED | 3 W | 50,000 hours |

| Color | Quantity | Current |
|-----------|----------|------------|
| Tri-color | 14 | 350 mA x 3 |

| Photo Optic | Parameter | |
|-------------|-------------------|---------|
| | Illuminance @ 5 m | 806 lx |
| | Beam angle | 15° |
| | Field angle | 28° |
| | Strobe rate | 0~20 Hz |

| Thermal | Max. External Temperature | Cooling System |
|---------|---------------------------|----------------|
| | 104 °F (40 °C) | Convection |

| DMX | I/O Connectors | Connector Type | Channel Range |
|-----|------------------|----------------|----------------|
| | 3- and 5-pin XLR | Sockets | 3, 4, 5, 9, 13 |

| Ordering | Product | Item Code | Item Number |
|----------|----------------------|-----------|--------------|
| | COLORado™ 1-TRI TOUR | 01030097 | 781462204228 |

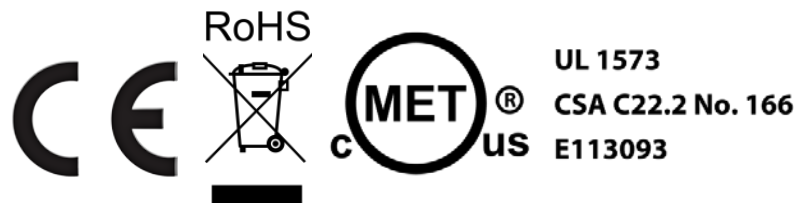

Contact Us **World Headquarters**

CHAUVET®

General Information

Address: 5200 NW 108th Avenue
Sunrise, FL 33351
Voice: (954) 577-4455
Fax: (954) 929-5560
Toll free: (800) 762-1084

Technical Support

Voice: (954) 577-4455 (Press 4)
Fax: (954) 756-8015
Email: tech@chauvetlighting.com

World Wide Web

www.chauvetlighting.com

United Kingdom and Ireland

CHAUVET® Europe Ltd.

General Information

Address: Unit 1C
Brookhill Road Industrial Estate
Pinxton, Nottingham, UK
NG16 6NT
Voice: +44 (0)1773 511115
Fax: +44 (0)1773 511110

Technical Support

Email: uktech@chauvetlighting.com

World Wide Web

www.chauvetlighting.co.uk

Outside the U.S., United Kingdom, or Ireland, contact your dealer. Follow their instructions to request support or to return a product. Visit our website for contact details.